

# Series 280

## Economy AC LVDTs

The Series 280 AC LVDTs are designed and manufactured to provide an accurate, yet economical, means of measuring linear displacement. The transducers are available in working ranges of 0.1 to 2.0 inches. Maximum non-linearity is specified as  $\pm 0.4\%$  of full scale.

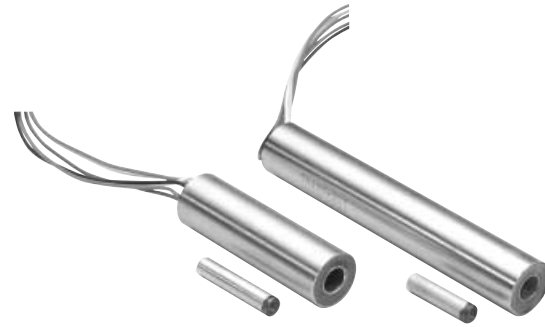

### KEY FEATURES

- Ranges from  $\pm 0.05''$  to 2.0''
- Large Core to Bore Clearance
- Non-linearity  $\leq 0.4\%$
- Low Cost

### SPECIFICATIONS - ELECTRICAL

MODEL	LINEAR RANGE $\pm$ Inches (mm)	REFERENCE FREQUENCY	SENSITIVITY V/in./V	INPUT IMPEDANCE Ohms	OUTPUT IMPEDANCE Ohms	PHASE ANGLE UNCOMPENSATED	FREQUENCY FOR ZERO PHASE SHIFT	MAXIMUM NON-LINEARITY	MAXIMUM EXCITATION
0280-0000	0.050 (1.27)	1.0 KHz	4.5	71	935	3°	1.6 KHz	$\pm 0.4\%$ Full Scale	1.0 V.A.
0281-0000	0.100 (2.54)	1.0 KHz	3.2	70	372	3°	1.4 KHz		
0282-0000	0.250 (6.35)	2.4 KHz	2.9	46	160	25°	17 KHz		
0283-0000	0.500 (12.7)	2.4 KHz	1.8	107	265	15°	10 KHz		
0284-0000	1.00 (25.4)	2.4 KHz	0.95	100	134	9.5°	7.8 KHz		

#### Notes:

1. Electrical specifications are based on energizing the primary coil with the specified excitation frequency.
2. Nominal values are given for sensitivity.
3. Operating Temperature -50°F to +250°F (-46°C to +121°C)

### SPECIFICATIONS - MECHANICAL

MODEL	HOUSING LENGTH A Inches (mm)	CORE LENGTH B Inches (mm)	ELECTRICAL CENTER C Inches (mm)	INNER SLEEVE MATERIAL	TOTAL NET WEIGHT W/O CORE Grams	CORE NET WEIGHT Grams	CORE PART NUMBER	LEAD LENGTH, GAUGE
0280-0000	1.63 (41.4)	1.00 (25.4)	0.63 (16.0)	PHENOLIC	40	5.4	C005-0046	7" AWG #26
0281-0000	1.94 (49.3)	1.19 (30.2)	0.78 (19.8)	PHENOLIC	48	6.4	C005-0045	7" AWG #26
0282-0000	3.31 (84.1)	1.25 (31.8)	1.47 (37.3)	PHENOLIC	67	7.0	C005-0044	7" AWG #26
0283-0000	4.88 (124)	2.00 (50.8)	2.25 (57.2)	PHENOLIC	105	12.1	C005-0037	7" AWG #26
0284-0000	6.88 (175)	3.00 (76.2)	3.25 (82.6)	PHENOLIC	120	18.4	C005-0038	7" AWG #26

**DIMENSIONAL DIAGRAM**

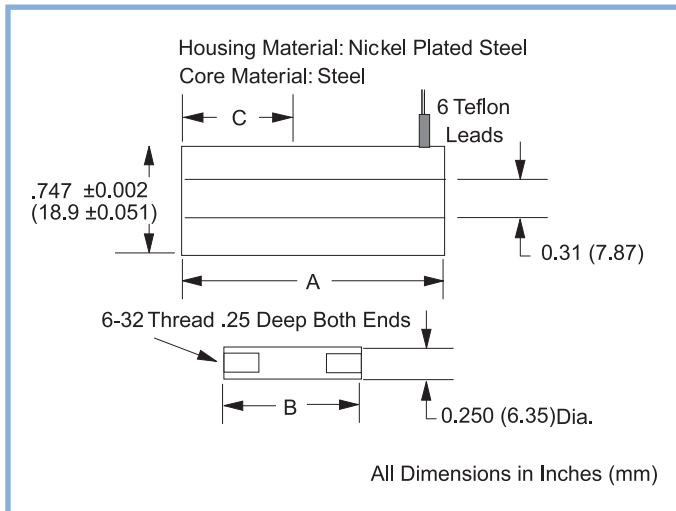

**SCHEMATIC**

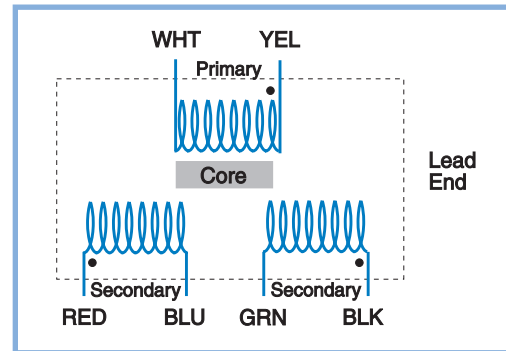

**CORE EXTENSION RODS (Sold Separately)**

The recommended core extension rods are made of nonmagnetic stainless steel and are sized to allow the transducers to operate over their full range. Extension rods from models with longer strokes may be used to facilitate installation. Using extension rods shorter than recommended may reduce the LVDT's usable measurement range.

MODEL	LENGTH L Inches (mm)	CORE EXTENSION ROD
0280-0000	2.00 (50.8)	C006-0060
0281-0000	2.00 (50.8)	C006-0060
0282-0000	2.50 (63.5)	C006-0061
0283-0000	3.25 (82.6)	C006-0062
0284-0000	5.25 (133)	C006-0063

**DIMENSIONAL DIAGRAM**

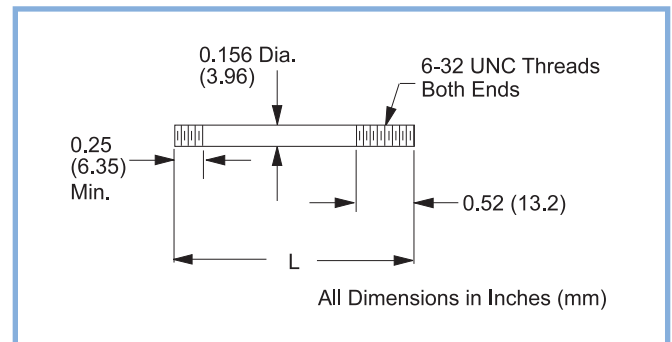

**SALES OPTIONS**

Option #	Description
X0009	Provide longer leads to a specified length
X0012	Replace leads with an integral connector type MS3101A-14S-6P; adaptor for connector has 1.00" O.D.; mating connector included

For more detailed information about these options, please contact the factory.

# Series 290

## General Purpose AC LVDTs

The Series 290 AC LVDTs are general purpose transducers designed to operate in most industrial environments. All units are terminated in 6 leads, allowing convenient connection to most conditioning electronics.



### KEY FEATURES

- Ranges from  $\pm 0.05''$  to  $6.0''$
- High Input Impedance
- Non-linearity  $\leq 0.5\%$
- $0.5''$  and  $0.75''$  Outer Diameter

### SPECIFICATIONS - ELECTRICAL

MODEL	LINEAR RANGE $\pm$ Inches (mm)	REFERENCE FREQUENCY	SENSITIVITY V/in./V	INPUT IMPEDANCE Ohms	OUTPUT IMPEDANCE Ohms	PHASE ANGLE UNCOMPENSATED	FREQUENCY FOR ZERO PHASE SHIFT	MAXIMUM EXCITATION
0290-0000	0.050 (1.27)	10.0 KHz	2.6	1550	860	-3.6°	7.0 KHz	1.0 V.A.
0291-0000	0.100 (2.54)	5.0 KHz	3.9	740	1790	0°	5.0 KHz	1.0 V.A.
0292-0000	0.250 (6.35)	2.4 KHz	1.6	2100	813	9.3°	30 KHz	1.0 V.A.
0293-0000	0.500 (12.7)	2.4 KHz	0.75	800	156	11°	10 KHz	1.0 V.A.
0294-0000	1.00 (25.4)	2.4 KHz	0.61	458	194	9.3°	9.3 KHz	1.0 V.A.
0295-0000	2.00 (50.8)	2.4 KHz	0.41	2050	520	7°	6.4 KHz	1.0 V.A.
0296-0000	3.00 (76.2)	2.4 KHz	0.23	1360	356	14°	6.8 KHz	1.0 V.A.

#### Notes:

1. Electrical specifications are based on energizing the primary coil with the specified excitation frequency.
2. Nominal values are given for sensitivity.
3. Operating Temperature -50°F to +250°F (-46°C to +121°C)

### SPECIFICATIONS - MECHANICAL

MODEL	HOUSING LENGTH A Inches (mm)	CORE LENGTH B Inches (mm)	ELECTRICAL CENTER C Inches (mm)	INNER SLEEVE MATERIAL	TOTAL NET WEIGHT W/O CORE Grams	CORE NET WEIGHT Grams	CORE PART NUMBER	LEAD LENGTH, GAUGE
0290-0000	0.88 (22.3)	0.56 (14.2)	0.34 (8.64)	PHENOLIC	14	0.4	C005-0003	7" AWG #30
0291-0000	1.06 (27.0)	0.81 (20.6)	0.46 (11.7)	PHENOLIC	17	0.7	C005-0007	7" AWG #30
0292-0000	3.21 (81.5)	1.75 (44.5)	1.40 (35.6)	S.S.	56	2.5	C005-0054	18" AWG #26
0293-0000	3.71 (94.2)	1.50 (38.1)	1.65 (41.9)	S.S.	65	2.0	C005-0055	18" AWG #26
0294-0000	4.71 (120)	1.75 (44.5)	2.15 (54.6)	S.S.	74	2.5	C005-0054	18" AWG #26
0295-0000	8.21 (209)	2.50 (63.5)	3.90 (99.1)	S.S.	116	3.6	C005-0056	18" AWG #26
0296-0000	10.52 (267)	2.00 (50.8)	5.30 (134)	S.S.	136	2.8	C005-0048	18" AWG #26

**DIMENSIONAL DRAWING**

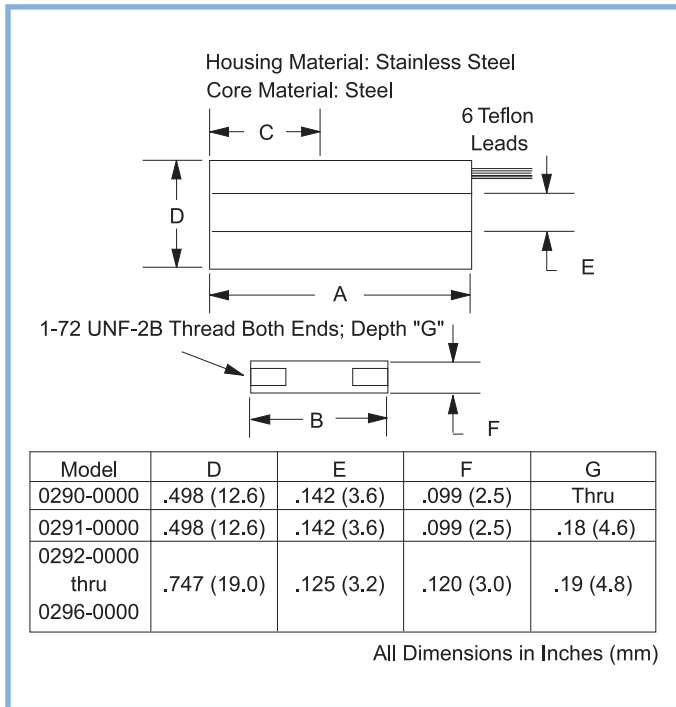

**SCHEMATIC**

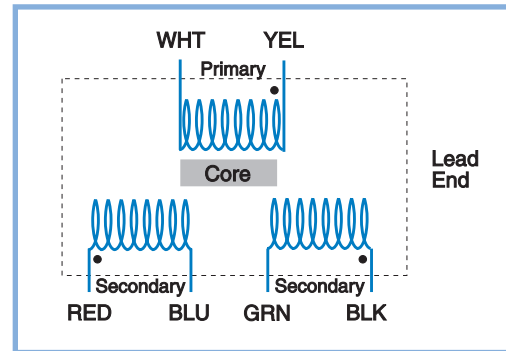

**CORE EXTENSION RODS** *(Sold Separately)*

The recommended core extension rods are made of nonmagnetic stainless steel and are sized to allow the transducers to operate over their full range. Extension rods from models with longer

strokes may be used to facilitate installation. Using extension rods shorter than recommended may reduce the LVDT's usable measurement range.

MODEL	LENGTH L Inches (mm)	CORE EXTENSION ROD
0290-0000	2.00 (50.8)	C006-0056
0291-0000	2.00 (50.8)	C006-0056
0292-0000	2.00 (50.8)	C006-0056
0293-0000	3.25 (82.6)	C006-0057
0294-0000	5.25 (133)	C006-0058
0295-0000	8.40 (213)	C006-0059
0296-0000	8.40 (213)	C006-0059

**DIMENSIONAL DRAWING**

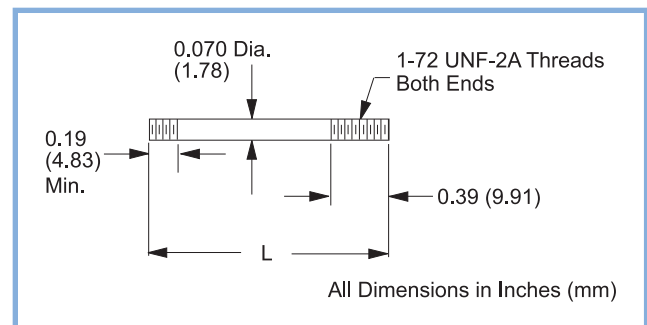

**SALES OPTIONS**

Option #	Description
X0001	Splashproof - protects the unit from washdown environments or outdoor applications. Applies to Models 0292-0000 through 0296-0000
X0009	Provide longer leads to a specified length
X0012	Replace leads with an integral connector type MS3101A-14S-6P; adaptor for connector has 1.00" O.D.; mating connector included
X0036	Welded non-lead end. Applies to Models 0292-0000 through 0296-0000

For more detailed information about these options, please contact the factory.