

Series 100

Linear Velocity Transducers

The Series 100 Linear Velocity Transducers provide a simple yet accurate means of measuring linear velocity. They consist of high coercive force permanent magnet cores which induce sizable DC voltage while moving concentrically within shielded coils. The basic design permits operation **without external excitation** while the generated output voltage varies linearly with core (magnet) velocity. These transducers are ideal for seismology, hydraulic ram speed, drilling rate, and any other application where an instantaneous velocity measurement is required.

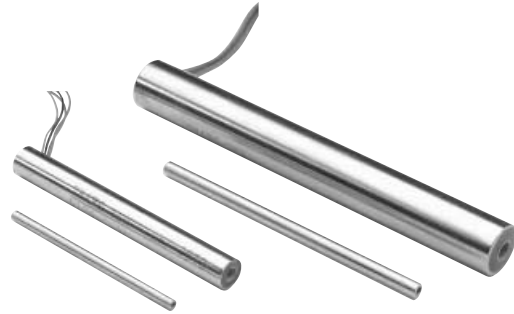

KEY FEATURES

- Self-Generating DC Voltage Output
- Magnetically Shielded
- High Sensitivity
- High Frequency Response

ELECTRICAL SPECIFICATIONS

MODEL NUMBER	MAGNET DIMENSIONS Inches (mm)		NOM. OUTPUT SENSITIVITY mV/in/sec (mV/mm/sec)	ELECTRICAL IMPEDANCE Coils Connected in Series		REPLACEMENT MAGNETS	FREQUENCY RESPONSE* Hz	
	WORKING RANGE	USABLE RANGE	Open Circuit	R Ohms	L Henries	Magnet Number	Load = 10R	Load = 100R
0100-0000	0.5 (12)	1.3 (33)	120 (5)	2000	0.085	M000-0000	350	1500
0100-0001	0.5 (12)	1.3 (33)	54 (2)	2000	0.085	M000-0008	350	1500
0101-0000	1.0 (25)	1.9 (48)	90 (4)	2500	0.065	M000-0001	600	1500
0101-0001	1.0 (25)	1.9 (48)	40 (2)	2500	0.065	M000-0009	600	1500
0111-0000	1.0 (25)	2.3 (58)	550 (22)	13000	1.6	M000-0002	120	600
0111-0001	1.0 (25)	2.3 (58)	250 (10)	13000	1.6	M000-0010	120	600
0112-0000	2.0 (50)	3.4 (86)	550 (22)	19000	2.9	M000-0003	100	500
0112-0001	2.0 (50)	3.4 (86)	250 (10)	19000	2.9	M000-0011	100	500
0113-0000	3.0 (75)	4.2 (107)	550 (22)	25000	3.2	M000-0004	120	500
0113-0001	3.0 (75)	4.2 (107)	250 (10)	25000	3.2	M000-0012	120	500
0114-0000	4.0 (100)	5.5 (140)	550 (22)	32000	4.0	M000-0005	120	400
0114-0001	4.0 (100)	5.5 (140)	250 (10)	32000	4.0	M000-0013	120	400
0122-0000	6.0 (150)	8.0 (203)	425 (17)	11500	1.9	M000-0006	95	450
0122-0001	6.0 (150)	8.0 (203)	160 (6)	11500	1.9	M000-0014	95	450
0123-0000	9.0 (225)	11.0 (279)	425 (17)	17000	2.8	M000-0007	95	450
0123-0001	9.0 (225)	11.0 (279)	160 (6)	17000	2.8	M000-0015	95	450
0124-0001	12.0 (300)	15.0 (381)	175 (7)	22000	3.7	M000-0023	95	450
0125-0001	16.5 (412)	18.5 (470)	175 (7)	29000	5.1	M000-0024	90	430
0126-0001	20.0 (500)	22.0 (559)	175 (7)	34000	6.2	M000-0025	90	430
0127-0001	24.0 (600)	26.0 (660)	175 (7)	42000	7.3	M000-0028	90	430

Operating Temperature Range: -50°F to +200°F (-46°C to +93°C)
Max. Non-Linearity: < ±2.5% of Reading

* Output voltage is attenuated < 1% of the constant velocity value.

Polarity of Output: Voltage at Red lead is positive with respect to that at Black when north pole of magnet is closest to, and traveling towards, lead end of LVT.

Tel: 800-828-3964 Fax: 860-872-4211
860-872-8351 Web: www.transtekinc.com

MECHANICAL SPECIFICATIONS

MODEL NUMBER	COIL HOUSING DIMENSIONS, Inches (mm)					MAGNET DIMENSIONS, Inches (mm)			
	C_A	L_A	$(OD)_A$	$(ID)_A$	WEIGHT W_A Grams	L_C	$(OD)_C$	THREAD	WEIGHT W_C Grams
0100-0000	1.34 (34)	3.17 (81)	0.374 (9.5)	0.13 (3.3)	20	2.38 (60)	0.125 (3.2)	1-72 NF	3.5
0100-0001	1.34 (34)	3.17 (81)	0.374 (9.5)	0.13 (3.3)	20	1.63 (41)	0.125 (3.2)	1-72 NF	2.5
0101-0000	1.88 (48)	4.24 (108)	0.374 (9.5)	0.13 (3.3)	25	3.00 (76)	0.125 (3.2)	1-72 NF	4.5
0101-0001	1.88 (48)	4.24 (108)	0.374 (9.5)	0.13 (3.3)	25	2.25 (57)	0.125 (3.2)	1-72 NF	3.8
0111-0000	2.25 (57)	5.06 (129)	0.624 (15.9)	0.19 (4.8)	110	3.50 (89)	0.187 (4.8)	4-40 NC	11
0111-0001	2.25 (57)	5.06 (129)	0.624 (15.9)	0.19 (4.8)	110	2.75 (70)	0.187 (4.8)	4-40 NC	10
0112-0000	3.25 (83)	7.06 (179)	0.624 (15.9)	0.19 (4.8)	150	4.50 (114)	0.187 (4.8)	4-40 NC	15
0112-0001	3.25 (83)	7.06 (179)	0.624 (15.9)	0.19 (4.8)	150	3.75 (95)	0.187 (4.8)	4-40 NC	14
0113-0000	4.25 (108)	9.06 (230)	0.624 (15.9)	0.19 (4.8)	200	5.25 (133)	0.187 (4.8)	4-40 NC	17
0113-0001	4.25 (108)	9.06 (230)	0.624 (15.9)	0.19 (4.8)	200	4.50 (114)	0.187 (4.8)	4-40 NC	16
0114-0000	5.38 (137)	11.31 (287)	0.624 (15.9)	0.19 (4.8)	240	6.75 (171)	0.187 (4.8)	4-40 NC	22
0114-0001	5.38 (137)	11.31 (287)	0.624 (15.9)	0.19 (4.8)	240	6.00 (152)	0.187 (4.8)	4-40 NC	21
0122-0000	7.63 (194)	15.81 (402)	0.749 (19)	0.30 (7.6)	420	9.25 (235)	0.25 (6.3)	4-40 NC	54
0122-0001	7.63 (194)	15.81 (402)	0.749 (19)	0.30 (7.6)	420	8.50 (216)	0.23 (5.8)	4-40 NC	51
0123-0000	11.1 (282)	22.81 (579)	0.749 (19)	0.30 (7.6)	610	11.75 (298)	0.25 (6.3)	4-40 NC	69
0123-0001	11.1 (282)	22.81 (579)	0.749 (19)	0.30 (7.6)	610	11.00 (279)	0.23 (5.8)	4-40 NC	66
0124-0001	14.1 (358)	29.00 (737)	0.749 (19)	0.30 (7.6)	810	14.25 (362)	0.23 (5.8)	4-40 NC	88
0125-0001	18.6 (472)	38.00 (965)	0.749 (19)	0.30 (7.6)	1120	18.75 (476)	0.23 (5.8)	4-40 NC	121
0126-0001	22.1 (561)	45.00 (1143)	0.749 (19)	0.30 (7.6)	1360	22.25 (565)	0.23 (5.8)	4-40 NC	147
0127-0001	26.1 (663)	53.00 (1346)	0.749 (19)	0.30 (7.6)	1520	26.25 (667)	0.23 (5.8)	4-40 NC	156

FIXTURING FOR LINEAR OPERATION

Unlike LVDTs, these transducers do not produce a voltage output unless the magnet is moving. This makes it impossible to electrically identify the correct location of the magnet for linear operation. Users must mechanically position the magnet in the LVT at a known reference point.

As shown in the Dimensional Drawing, the location of the electrical center of the coils is known, and can be used as a reference point. The midpoint of the linear stroke is found by aligning the center of the magnet, C_C , with the electrical center, C_A , of the coils. Once in position, the magnet can be moved 1/2 the linear range in either direction.

The transducer housing can be secured with a split block or clamping arrangement. The use of set screws should be avoided, as this may cause internal damage if overtightened.

DIMENSIONAL DIAGRAM

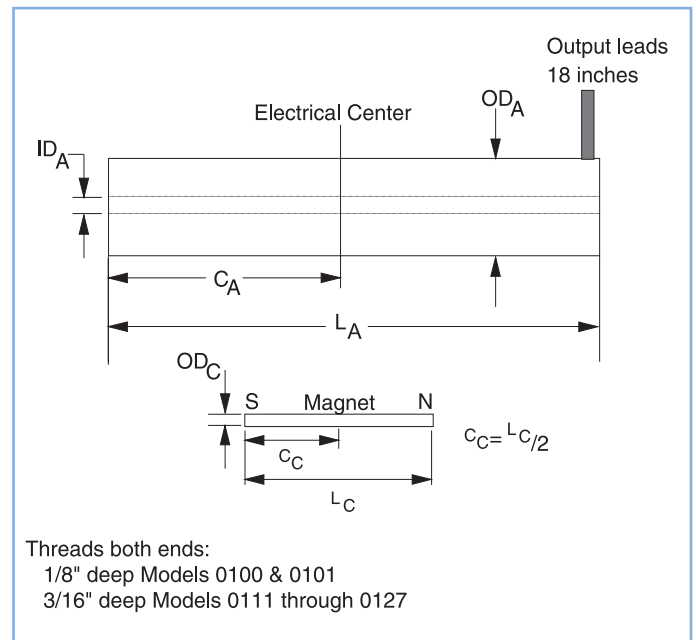

CORE EXTENSION RODS *(Sold Separately)*

The recommended core extension rods are made of nonmagnetic stainless steel and are sized to allow the transducers to operate over their full range. Extension rods from models with longer

strokes may be used to facilitate installation. Using extension rods shorter than recommended may reduce the LVT's usable measurement range.

CORE EXTENSION ROD	LENGTH L Inches (mm)	RECOMMENDED FOR USE WITH TRANSDUCER MODEL
0.070 inch (1.78 mm) diameter rod with 1-72 UNF-2A Thread both ends		
C006-0057	3.255 (82.68)	0100-0000/ -0001 0101-0000/ -0001
0.113 inch (2.87 mm) diameter rod with 4-40 UNC-2A Thread both ends		
C006-0233	3.50 (88.9)	0111-0000/ -0001
C006-0234	4.50 (114.3)	0112-0000/ -0001
C006-0235	5.50 (139.7)	0113-0000/ -0001
C006-0236	6.50 (165.1)	0114-0000/ -0001
0.187 inch (4.75 mm) diameter rod with 4-40 UNC-2A Thread one end, 10-32 UNF-2A Thread other end		
C006-0072	8.50 (215.9)	0122-0000/ -0001
C006-0073	13.00 (330.2)	0123-0000/ -0001
C006-0074	16.00 (406.4)	0124-0001
C006-0075	20.50 (520.7)	0125-0001
C006-0076	24.00 (609.6)	0126-0001
C006-0121	28.00 (711.2)	0127-0001

