

Series 1000

Oscillator/Demodulator

The Series 1000 Oscillator/Demodulators provide complete electrical support for AC LVDTs. Working from an unregulated DC input, the modules generate a stable sinusoidal excitation voltage for the transducer. The LVDT's secondary voltages are converted into DC voltage by the module's phase sensitive demodulator. The demodulator has automatic phase synchronization which simplifies installation and setup by eliminating the need to make phase angle adjustments for each transducer. An active, three-pole filter in the final stage reduces output ripple while maximizing frequency response. Other features include zero and span controls, full encapsulation, threaded inserts for mounting, and self locking terminal strips.



KEY FEATURES

- Works with 5 and 6 wire LVDTs
- Internally Regulated
- DC Voltage or 4-20 mA Output
- High Frequency Response

ELECTRICAL SPECIFICATIONS

INPUT POWER	Voltage	± 14.5 to ± 28 VDC, Input polarity protected NOTE: DUAL DC OUTPUT POWER SUPPLY REQUIRED
	Current	± 150 mA Max. plus LVDT current
OSCILLATOR OUTPUT TO LVDT	Voltage	4.25 to 5.75 VRMS adjustable via 15 turn span control
	Current	Will drive LVDTs with primary impedance of 100 Ohms or greater. Short circuit and thermally protected
SIGNAL OUTPUT - VOLTAGE	Voltage	DC output is 2 times the RMS output of the LVDT. Output voltage is limited to ± 12 VDC.
	Current	± 3 mA without distortion
MODELS 1000-0011, 1000-0012, 1000-0014	Impedance	Less than 5 Ohms
	Ripple	0.015 VRMS Max.
	Current	4-20 mA output with LVDT whose sensitivity is 0.5 V/V ($\pm 10\%$). Min. Full Scale Output current: 2-22 mA
MODELS 1000-0021, 1000-0022, 1000-0024	Load Impedance	$> 1 \times 10^{10}$ Ohms; Operation into loop impedance between 5 and 400 Ohms.
	ACCURACY	Non-linearity $\pm 0.05\%$ Max. over ± 10 VDC output Temp. Coef. $< \pm 0.00025\text{V}/^\circ\text{F}$ Zero, $< \pm 0.01\%$ output/ $^\circ\text{F}$ Span
TEMPERATURE RANGE	Operating	$+32^\circ\text{F}$ to $+158^\circ\text{F}$ (0°C to $+70^\circ\text{C}$)
	Storage	-67°F to $+257^\circ\text{F}$ (-55°C to $+125^\circ\text{C}$)
ZERO ADJUSTMENT		± 0.40 Min. VDC via 15 turn zero control
TERMINAL CONNECTIONS		Friction terminals with self locking screws, accepts up to #16 AWG wire.

BLOCK DIAGRAM

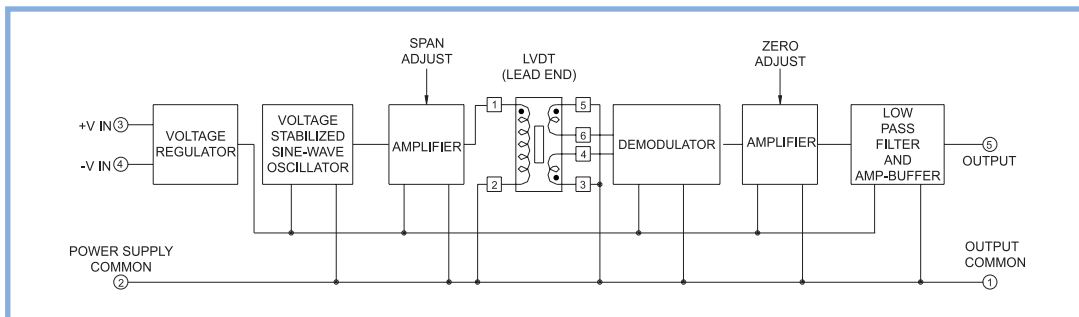

INTERCONNECTION DIAGRAM

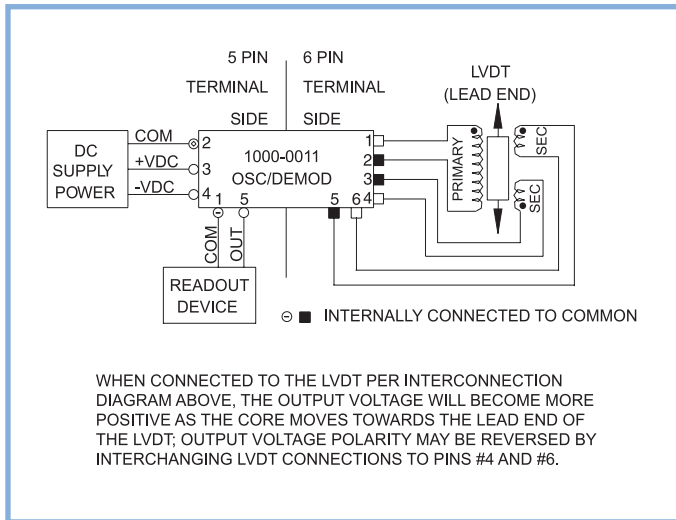

DIMENSIONAL DIAGRAM

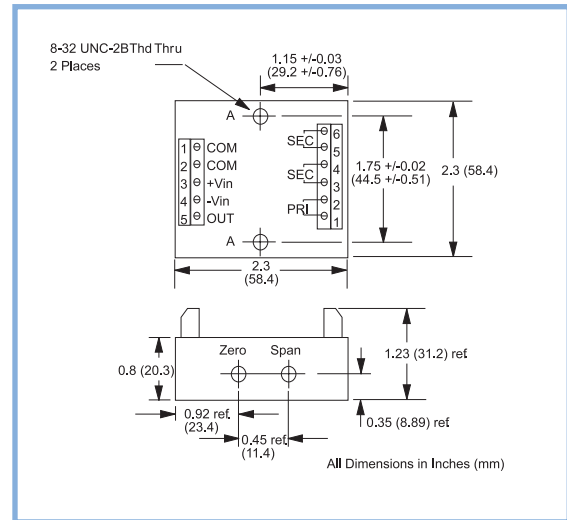

NOTE:

- 4 wire LVDT connection requires access to the center connection of both secondaries. One wire from each of the secondaries and the primary will be tied together and attached to COMMON. The remaining three leads will be connected as shown in the connection diagram.

VOLTAGE AND 4-20 MA OUTPUT VERSIONS

The equivalent models for voltage and 4-20 mA output are shown in the table below, along with frequency, phase angle and frequency response for each. All of these modules are physically

identical and require the same dual bipolar voltage supply. The output pins 5 and 1 are used for the current output.

VDC MODEL	4-20 mA MODEL	FREQUENCY KHz ±10%	LVDT PHASE ANGLE	FREQUENCY RESPONSE, Hz
1000-0011	1000-0021	3	ALL	> 500
1000-0012	1000-0022	7	> 10 Degrees	> 1000
1000-0014	1000-0024	7	< 10 Degrees	> 1000

Note: Current Loop impedance must be between 5 and 400 Ohms for linear operation.

SALES OPTIONS

Option #	Description
X0003:	Provide special zero offset and/or sensitivity
X0005:	Provide special cutoff frequency