

Angular Displacement Transducer 360° Precision Feedback and Display

The Model 0607-0001 Optical Encoder and Model 1004-0000 Counter Display system provides precision feedback and readout of shaft angular displacement over the full 360° revolution. From a fixed or user settable point, angular position is displayed in degrees over indefinite shaft revolutions at speeds up to 3000 RPM, with equivalent BCD output. In simplest mode, Encoder position is displayed in increments of 0.05° over the range 0.00° to 359.95°. Display and Encoder are sold separately and will deliver full accuracy without adjustment.



KEY FEATURES

- **Displays Full 360° Working Range**
- **0.025° Accuracy and 0.05° Resolution**
- **Speeds to 3,000 RPM**
- **Binary-Coded-Decimal (BCD) Output**

Model 0607-0001 Optical Encoder

Model 0607-0001 is a rotary, incremental Encoder that outputs 1800 cycles of quadrature TTL signal and one zero reference pulse (Z_R) per shaft revolution. Compact size, low weight, and servo and/or bolt-face mounting make it easy to install, even where space is limited.

The Encoder's precision pilot diameter provides a reference for mounting the unit concentric to the shaft to be monitored. Four tapped holes in the face, or the servo slot on its circumference, provide two means for securing the body to the user's reference surface. Installation of a flexible shaft coupling (see Accessories section, pg. 4) is highly recommended to protect the Encoder from excessive misalignment or motion of the monitored shaft. Encoder cable can be soldered directly to the Display connector or can be extended (see Accessories section, pg. 4).

Model 1004-0000 Counter Display

Model 1004-0000 is a panel mount, 5-digit LED Display that excites the Encoder, decodes its output into 7200 counts/revolution, and displays the shaft angle position - in increments of 0.05° - from the last reset. It also provides latching, parallel BCD output that matches the displayed value. When tri-state enabled, the BCD output can be used as an 8-bit parallel, word serial, multiplexed signal for input into an 8-bit port.

The compact 1/8 DIN case, rear-panel set-up, and solder termination make it easy to install, even where space is limited. The Display installs directly through panels up to 0.20 inch (5.1 mm) thick, or can be used as a benchtop instrument. All necessary mating edge-type connectors are included, to which Encoder leads, 5 VDC power and any other required connections can be soldered directly (see Accessories section for appropriate Line Powered Supplies, pg. 4).

The base unit is available as Model 1004-00000. Unit with analog output option, providing ± 5.0 VDC over the range $\pm 359.95^\circ$, is available as Model 1004-00001.

Operation of Encoder/Display System

When installed, the Encoder body is typically secured to the reference surface and its shaft is fixed (preferably by a flexible coupling) to the shaft being monitored. Its leads are connected to the Display, which requires a 5 VDC external power source that can provide at least 450 mA of current. The Display can be programmed, either locally or remotely, by electrically shorting the proper pins (ref. jumpers F1, F2, etc.) at its connector. The Display reads directly in degrees and resets to 000.00° at each of the following: 1) at power-up; 2) anytime it reaches 360.00° (regardless of sign); 3) when the front panel RESET button is pressed; 4) when

F1 is closed for at least 0.01 seconds; and 5) at Z_R, only when F2 is closed. The Display is shipped with the following contacts open: F1, F2, F3, F4A and F4B. In this configuration, the display range is -359.95° to +359.95° and the displayed value increases while rotating the shaft in a clockwise direction (as viewed from the end of the shaft, looking towards the body). Closing F2 enables the reset at Z_R. Closing F3 changes the sense of the display to counterclockwise. Closing both F4A and F4B changes the display range to 000.00° to 359.95°.

Encoder Specifications

ELECTRICAL

Resolution Range	1800 cycles per revolution (7200 counts per revolution with external 4X counting when using A and B channel outputs)
Light Source	LED
Light Sensor	Photodiode
Excitation	5 VDC ±10%, 80 mA
Output Format	Two count channel outputs (A and B) in phase quadrature, plus zero reference Z _R ; all are TTL single ended square waves with rise and fall time of one microsecond maximum into 1,000 pF load
Z_R Reference	Full cycle
Frequency Response	Up to 100 kHz, all channels
Phase Sense	Channel A leads B for CW rotation of shaft (as viewed from shaft end, looking towards body)
Termination	Shielded cable with #24 AWG lead wires (see diagram below for lead color vs. function)

MECHANICAL

Shaft Loading	10 lb axially and radially, maximum; 100,000 radians/sec ² maximum angular acceleration
Shaft Radial Runout	0.001 inch (.025mm) T.I.R.
Bearing	R-4 shielded; 0.1 ounce-inch (7.2 gram-cm) maximum starting torque at 25°C
Operating Speed	3000 RPM maximum continuous
Materials	303 stainless steel shaft; aluminum pilot diameter and base; anodized aluminum cover
Weight	5 ounces (142 grams)

ENVIRONMENTAL

Temperature	-23°F to 158°F (-10°C to 70°C) Operating -31°F to 176°F (-35°C to 80°C) Storage
Shock	30 G's for 11 milliseconds maximum
Vibration	50 Hz, 10 G's for 1 hour
Humidity	To 98% R.H. (non-condensing)

Dimensional Diagram - Encoder

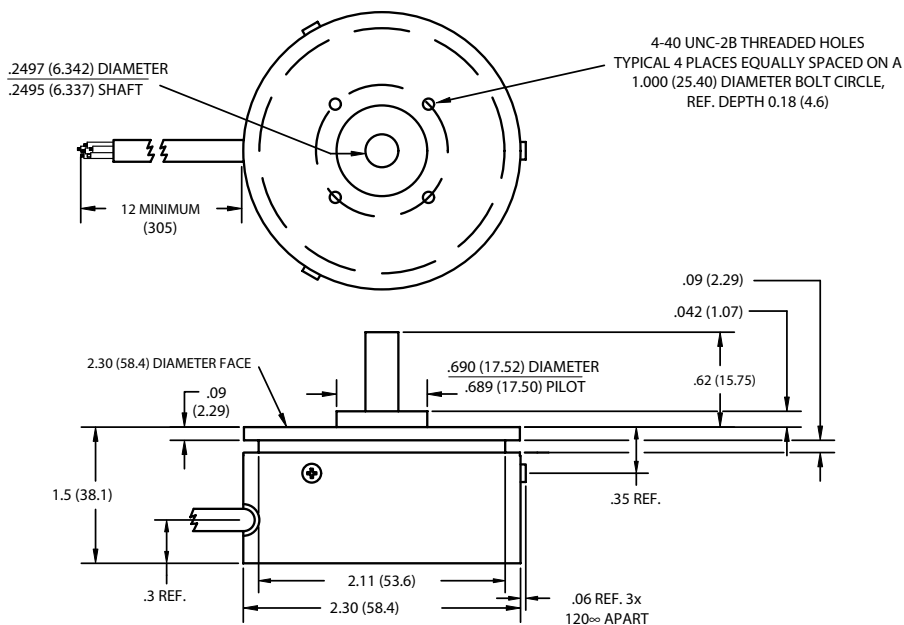

Encoder Lead Color vs. Function	Color	Function
White	Channel A Output	
Green	Channel B Output	
Yellow	Channel Z _R Output	
Black	Common	
Red	+5 VDC Input Power	

Timing Diagram for CW Rotation

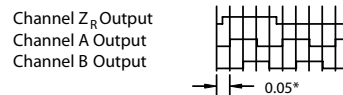

All Dimensions in Inches (mm)

Display Counter Specifications

ELECTRICAL

Resolution Range	0.05 count over range -359.95 to +359.95
Display Type	0.55 inch (14 mm) high red LEDs; 5 digits plus ± sign and decimal point
Excitation	5 VDC ±10%, 450 mA maximum (includes up to 250 mA to power encoder)
Signal Inputs	Accepts TTL level single-ended A, B, Z _R inputs or complementary A, A*, B, B*, Z _R , Z _R * inputs; with A and B, or A, A*, and B, B* inputs, input count is multiplied by four; the inputs pass through a single pole noise filter rolled off at 100 kHz
Output Signal	Latchable, TTL BCD outputs that correspond to the displayed value; also usable as full parallel 19-bit output (or, when logic is tri state enabled, as an 8-bit parallel word, serial multiplexed output)
Selectable Set-up Features	Closing F1 resets display to 000.00 Closing F2 enables reset at Z _R Closing F3 changes sense to CCW Closing F4/A/B selects range 000.00 - 359.95

Optional Analog Output Order as Model 1004-00001 (or without analog output option as 1004-00000)

Voltage Output	±5.0 VDC over ±359.95°
Accuracy	±0.1% over 77°F ±18°F (25°C ±10°C)

MECHANICAL

Size	1/8 DIN plastic case mounts through panel up to 0.20 inch (5.1 mm) thick (see diagram below)
Termination	Two rear panel 30-pin edge connectors with solder lugs

ENVIRONMENTAL

Temperature	32°F to 158°F (0°C to 70°C) Operating -13°F to 194°F (-25°C to 90°C) Storage
Shock	50 G's for 11 milliseconds maximum
Vibration	20 Hz to 2000 Hz at 5 G's maximum
Humidity	To 98% R.H. (non-condensing)

Current Draw	5 mA maximum
Short Circuit Protection	Indefinitely

Dimensional Diagram - Display Counter

PANEL CUTOUT: 3.65 (92.7) WIDE, 1.77 (45.0) HIGH

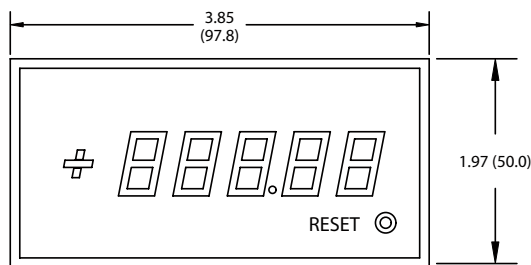

All Dimensions in Inches (mm)

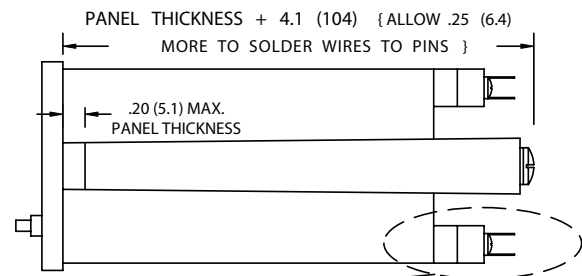
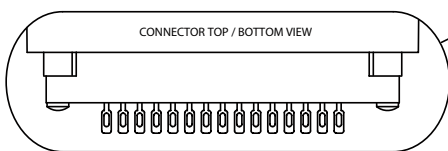

Display Closure (pin/pin) vs. Function

F1 (J2-4/J2-D) Momentary	Resets display to 000.00
F2 (J2-14/J2-R)	Enables Z _R
F3 (J2-11/J2-M)	Changes sense to CCW
F4 (J2-3/J2-C)	Selects range 000.00 to 359.95

Lower Connector J-1

Pin #	Function	Pin#	Function
1	Digit 1, Bit 8	A	Digit 1, Bit 4
2	Digit 1, Bit 1	B	Digit 1, Bit 2
3	Digit 2, Bit 4	C	Digit 2, Bit 8
4	Digit 2, Bit 1	D	Digit 2, Bit 2
5	Digit 1, Digit 2 Output Disable	E	Digit 3, Digit 4 Disable
6	BCD Latch (Low Latches)	F	Digit 3, Bit 8
7	Digit 3, Bit 4	H	Digit 3, Bit 1
8	Digit 3, Bit 2	J	Digit 4, Bit 8
9	Digit 4, Bit 4	K	Digit 5, Bit 8
10	Digit 4, Bit 1	L	Digit 5, Bit 4
11	Digit 4, Bit 2	M	Digit 5, Bit 1
12	Digit 5, Bit 2	N	Digit 5 Disable
13	O.F. Bit	P	+ Bit (High = +)
14		R	Display Latch (High Latches)
15	+5 Volts In	S	DC Common

Special wiring for J-1 Connector: 1) Pins 1, A & B not used
2) Connect Pin 2 to remote display Digit 1, Bit 1 & Digit 1, Bit 4

Upper Connector J-2

Pin #	Function	Pin#	Function
1		A	Analog Common
2		B	Analog Out
3	Mode 1 On (F4)	C	DC Common
4	Reset to Zero (F1, Momentary)	D	DC Common
5		E	-
6	Z from Encoder	F	Z̄ from Encoder (Not Used)
7	B from Encoder	H	B̄ from Encoder (Not Used)
8	A from Encoder	J	Ā from Encoder (Not Used)
9		K	+5 Volts to Encoder
10		L	DC Common to Encoder
11	Direction (F3)	M	DC Common
12	A Quad B X1	N	DC Common
13	A Quad B X2	P	DC Common
14	Z On (F2)	R	DC Common
15	+5 Volts In	S	DC Common In

Dimensional Diagram - Shaft Coupler

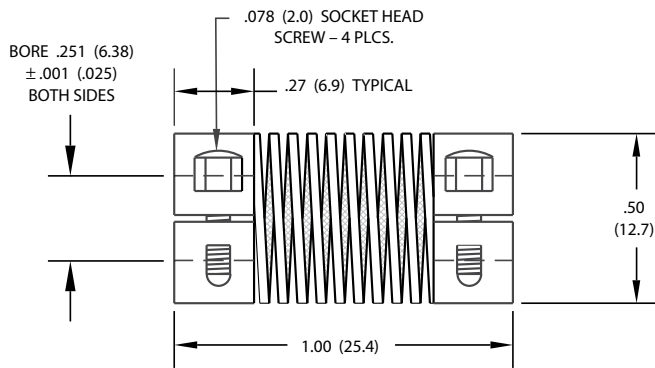

For applications with max. angular offset 5°, max. parallel offset .007 (.18), max. torque 71 ounce-inch (5130 g-cm)

All Dimensions in Inches (mm)

Dimensional Diagram - Power Supply

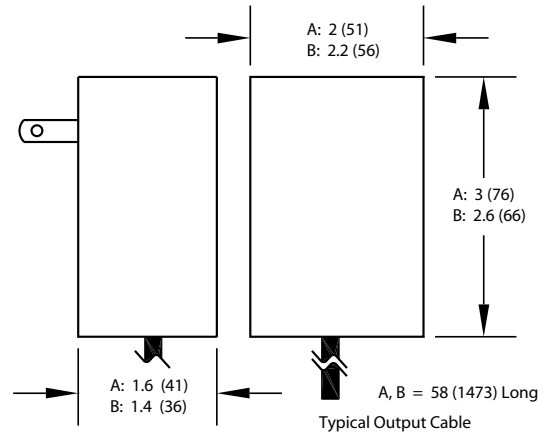

A = Model 1100-0000, B = Model 1100-0001

All Dimensions in Inches (mm)

Accessories (Sold Separately)

F001-0019	Flexible Shaft Coupling - (see dimensional diagram above)
C003-0008	Connector - when ordered on Encoder, leads are terminated in type MS3106A-14S-5P connector (Red lead to Pin A; White to B; Black to C; Yellow to D; Green to E)
C000-0046	Cable - vinyl jacketed, 15 ft. long*, terminated at one end in type MS3101A-14S-5S connector (mates with C003-0008) and leads at other end (Pin A to Red lead; B to Blue; C to Black; D to Brown; E to White; N/C to Green); operating temperature for Cable is -22°F to +176°F (-30°C to +80°C)
1100-0000	115 VAC Line Powered Supply - 95-130 VAC input (see dimensional diagram above)
1100-0001	230/115 VAC Line Powered Supply - 95-260 VAC input (see dimensional diagram above)

*Optionally available to 100 ft., but lengths longer than 25 ft. may limit Frequency Response; specify length if not 15 ft.



Route 83, P.O. Box 338 Ellington, CT 06029

800-828-3964

Ph: 860-872-8351 Fx: 860-872-4211 www.transtekinc.com e-mail: sales@transtekinc.com

Orders can be placed directly with Trans-Tek, Inc., or with any of our Sales Representatives. Orders may be placed by telephone, mail, e-mail or FAX (verbal telephone orders should be followed by written confirmation). Unless specifically requested, UPS Ground transportation will be used. Shipping charges will be prepaid and added to the order for all domestic shipments unless otherwise specified. All international shipments will be sent Freight Collect (or can be prepaid and added to the order, as arranged with the customer).

Terms and Conditions

All prices are F.O.B. Ellington, CT, USA. Applicable federal, state, and local taxes are extra and paid by the buyer (except in CT where state tax will be prepaid and added to the invoice when applicable). Prices are subject to change without notice.

Trans-Tek, Inc.'s standard credit terms are NET 30 days with credit approval. Alternate methods of payment include: Cash-in-Advance, C.O.D., Mastercard, Visa and American Express.

International accounts are handled as Cash in Advance, with payment to be received by wire transfer or credit card. Full payment instructions are available upon request.

Minimum Order Requirement: \$50.00

Discounts

Quantity discounts are available. Please contact a factory representative for details.

Quotations

All written quotations by Trans-Tek, Inc. are valid for 30 days unless otherwise specified.

Warranty

All items listed herein are covered by warranty against defective materials and manufacturing for one year from date of shipment. This warranty is expressly limited to repair or replacement, at Trans-Tek, Inc.'s option, of the items involved. Other restrictions may apply.

Repairs/Returns

All repairs/returns require a Trans-Tek, Inc. Returned Material Authorization (RMA) number. The RMA number should be written on the outside of the package and on any supporting paperwork. All returns must be shipped to Trans-Tek, Inc. prepaid. Trans-Tek, Inc. will pay return shipping charges (UPS Ground, to U.S.A. points only) for all units repaired/replaced under warranty.

Revision: 06H