

ACCESSORIES – Supporting arms

MOD. 1 Vertical fixing

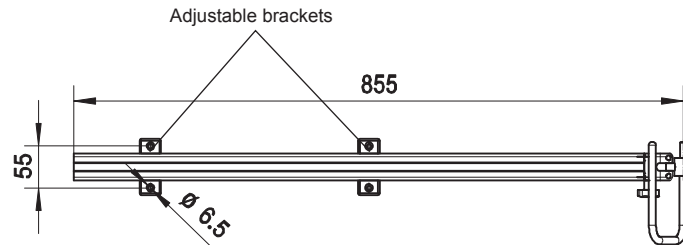

MOD. 2 Vertical fixing with single hinged arm

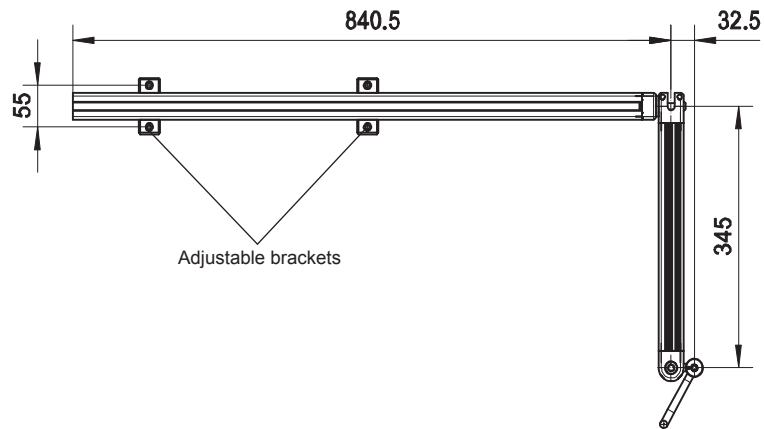

MOD. 3 Wall fixing with single hinged arm

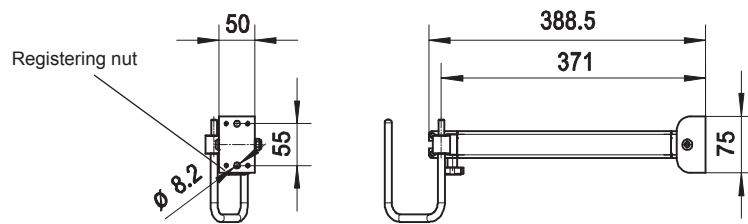

MOD. 4 Surface fixing with single hinged arm

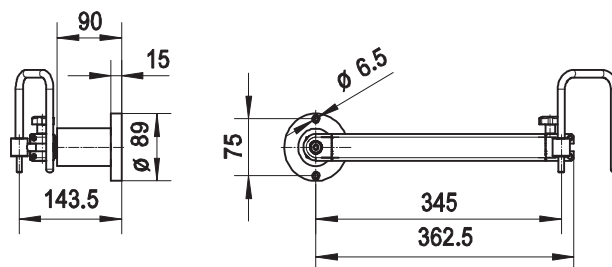

MOD. 5 Wall fixing with double hinged arm

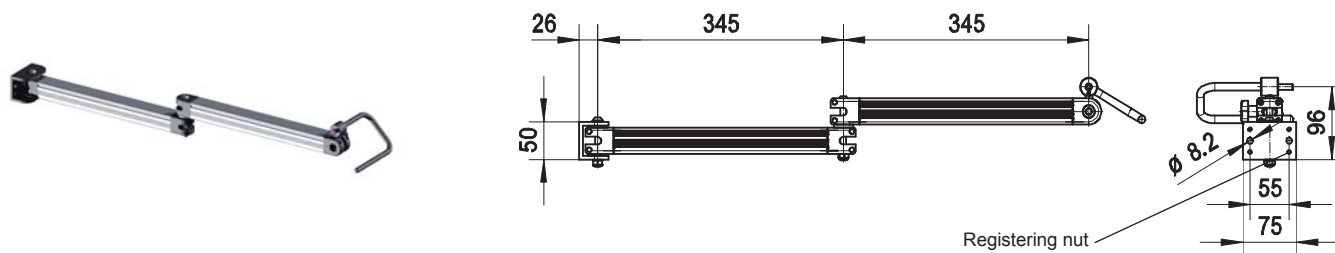

MOD. 6 Surface fixing with double hinged arm

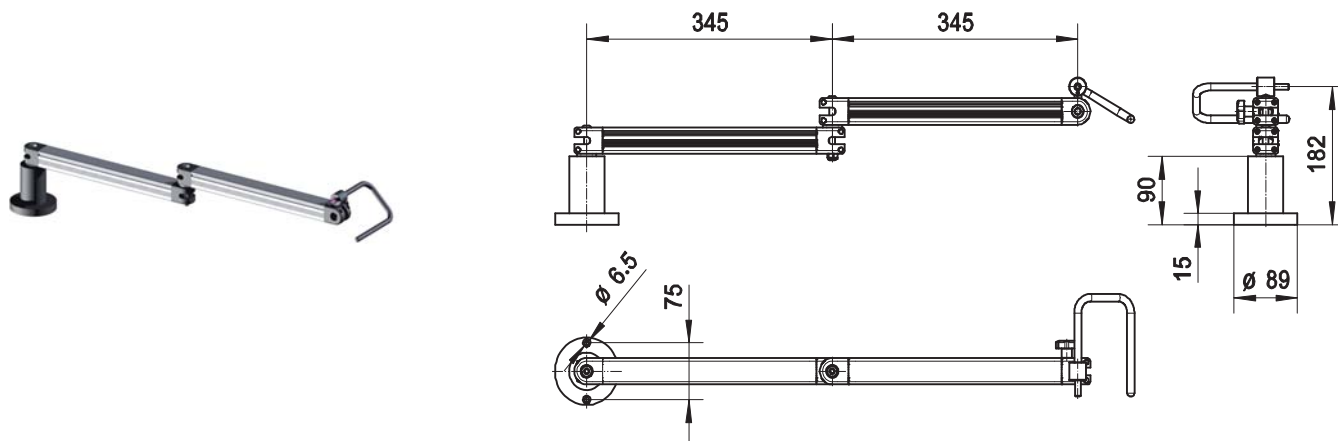

MOD. 7 Surface fixing

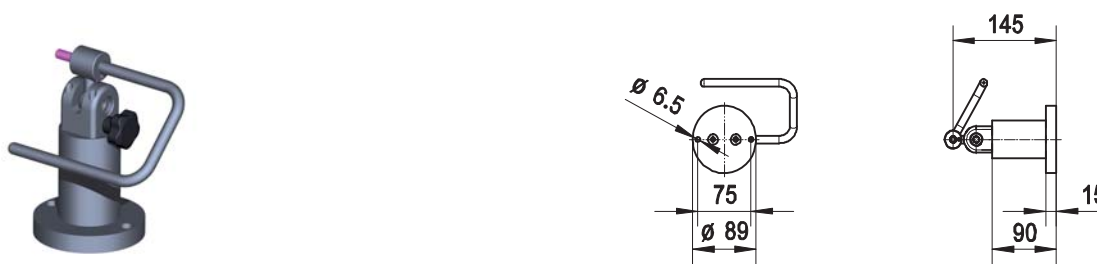

MOD. ARGO Vertical fixing on round bar Ø 25 mm

