



- **HIGH SENSITIVITY, LOW-PRESSURE SILICON DIE**

## DESCRIPTION

The SM5103 is a silicon micro-machined, piezoresistive low pressure sensing chip. These devices are available in full-scale ranges from 0.3 to 3.0 psi and are ideal for OEM and high volume applications.

Provided in die form, these sensors can be mounted on ceramic or PC board substrates as part of an OEM system. They also may be packaged into proprietary or application-specified sensor lines.

Die are probed, inked and diced, and shipped on tape.

Custom pressure ranges available in high-volume applications.

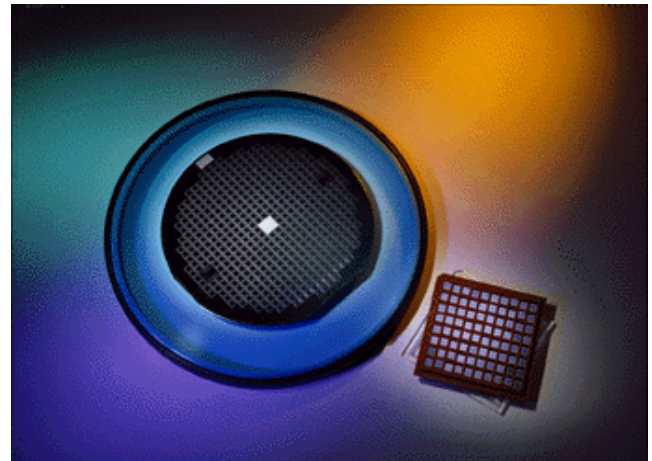

## FEATURES

- Low Pressure (from 0-0.3 to 0-3.0 PSI)
- High Performance at Low Pressures
- Constant Current or Constant Voltage Drive
- High Volume, Low Cost
- High Millivolt Output

## APPLICATIONS

- Air Flow
- Level Detection
- HVAC
- Instrumentation
- Gas Analysis

# SM5103

## CHARACTERISTICS FOR SM5103 - SPECIFICATIONS

All parameters are measured at 5.000V supply at room temperature, unless otherwise specified.

	Min.	Typ.	Max.	Units	Notes
Excitation Voltage	0	5.0	10.0	V	1
Excitation Current	0	1.5	3.0	mA	1
Span (FS Range)	0.3 PSI	25	50	mV	2
	0.8 PSI	25	50	mV	
	1.5 PSI	25	50	mV	
	3.0 PSI	25	50	mV	
Offset	-75	0	25	mV	
TC Span	-24	-19	-15.5	%FS/100°C	3
TC Offset	-7	-1	+7	%FS/100°C	3
TC Resistance	24	27.5	33	%/100°C	
Linearity	-0.3	+0.1	0.3	%FS	4
Bridge Impedance	2.7	3.3	4.0	kΩ	
Proof Pressure	10X			Rated FS	
Burst Pressure	15X			Rated FS	5
Operating Temperature	-40		125	°C	
Storage Temperature	-55		150	°C	

### Notes:

1. Bridge may be driven with positive or negative excitation as long as Vsub is not connected. SMI does recommend connecting the Vsub to the highest voltage in the bridge for added offset stability.
2. Measured at 5V constant voltage excitation.
3. Measured from 0 to 70 C
4. Defined as best straight line; 0.3 PSI linearity is ± 0.5% FS (max).
5. Burst Pressure is the pressure where the part can survive the overpressure but may degrade over repeated cycles.

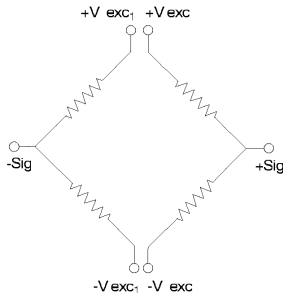

Positive output for pressure applied to the top (circuit) side of the sensor

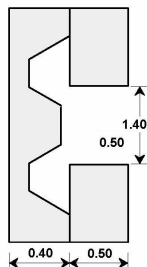

Die dimensions in mm

### ORDERING INFORMATION:

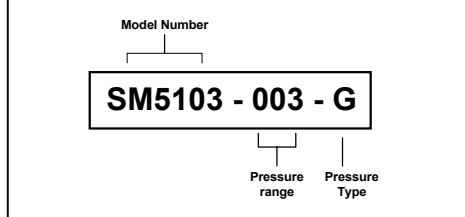

### Pressure Ranges

PSI	5103
0.3	003
0.8	008
1.5	015
3.0	030

Gage only.  
Custom ranges available  
in high volumes

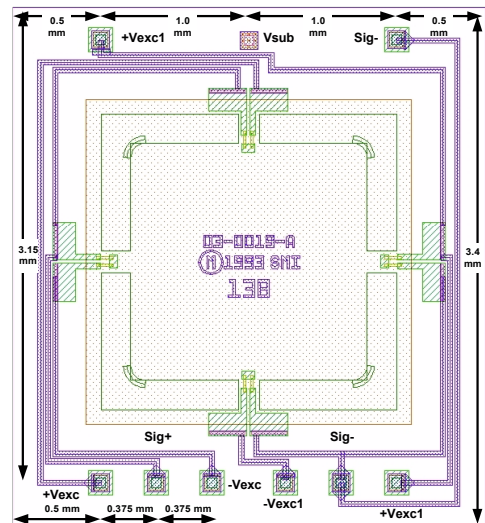

SM5103 Die (3.4X3.2 mm as sawn)  
Covered under USA Mask-Copyright

See separate Application Notes for typical range of variation in Saw dimensions.

### Notice:

Silicon Microstructures, Inc. reserves the right to make changes to the product contained in this publication. Silicon Microstructures, Inc. assumes no responsibility for the use of any circuits described herein, conveys no license under any patent or other right, and makes no representation that the circuits are free of patent infringement. While the information in this publication has been checked, no responsibility, however, is assumed for inaccuracies.

Silicon Microstructures, Inc. does not recommend the use of any of its products in life support applications where the failure or malfunction of the product can reasonably be expected to cause failure of a life-support system or to significantly affect its safety or effectiveness. Products are not authorized for use in such applications.